

# Operating Manual for Float-Controlled Condensate Trap

Type: WU – 1001N / 1002 / 1004 / 1101 / 1101N / 1201N / EF – 1080N / 1180 / 1180N / 1280N

Connections, depending on type: Flanges DIN / ANSI DN 15 – 50 /

Socket thread G ¾, G 1 / Welded ends, socket weldings

## 1.0 Safety instructions

### 1.1 Proper use

Any improper use, intervention in the design and deviation from the design data automatically lead to termination of the warranty. The from steam, compressed air and pressure gas systems. Any other use is not permissible. The manufacturer is not liable for damage resulting from any other use. The user or operator bears the risk in this case. This also applies analogously to incorrect assembly, startup, use and maintenance.

### 1.2 Warnings and symbols

- Personal risk due to escaping operating medium as well as because of pressure, temperature and weight. Failure to comply with these warnings results in the risk of accidents.
- Follow the instructions in this operating manual.
- The operator must ensure that this operating manual and, if necessary, other relevant documents are available on site.
- Only trained or instructed personnel may be employed here.
- Any mode of operation that may impair safety must be avoided.

## 2.0 General description and use

### 2.1 Design of the condensate trap (Figs. 1 – 9)

<u>Item</u>	
1	Top housing section
2	Housing gasket
3	Bottom housing section
4	Control valve
5	Housing bolts and nuts
6	Drain plug
7	Complete float control
8	Support body
9	Float assembly with fork
10	Support screw
	a) G ¾
	b) M 18 x 1.5
14	Control screw
15	Vent cap
16	Seal for vent cap
17	a) Complete plug valve
	b) Capsule with valve body
18	Set of hexagon socket screws
20	Seal for support screw
	a) G ¾
	b) M 18 x 1.5
28	Seal for plug valve / capsule with body
29	Seal for drain plug
30	Seal for control screw/valve

### 2.2 Identification and operating limits on rating plate or housing

- Manufacturer
- Year of manufacture
- Type and factory no.
- PS/TS
- CE mark for cat. 1 and 2 with No. 0525
- Housing material

Fig. 1

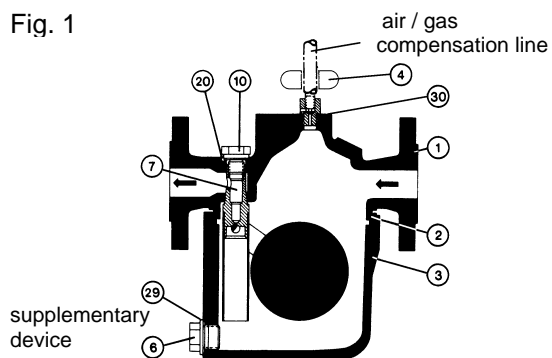

Type WU-1001, PN 16, DN 15 – 50

Fig. 2

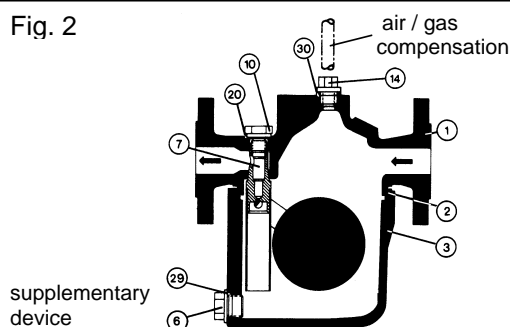

Type WU-1001-N, PN 16; WU-1101-N, PN25  
DN 15 – 50, stainless steel version

Fig. 3

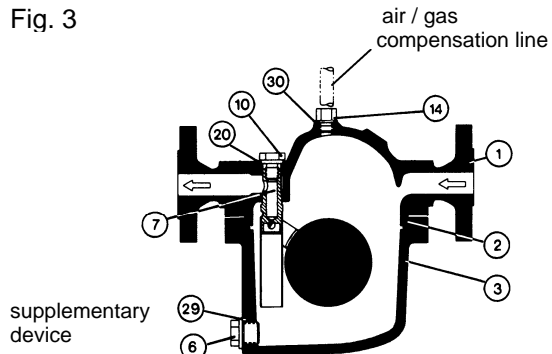

Type WU-1201-N, PN 40, DN 15 – 50,  
stainless steel version

Fig. 4

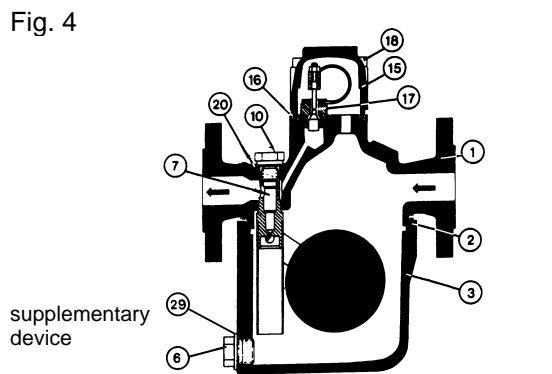

Type WU-1002, PN 16, DN 15 – 50

Fig. 6

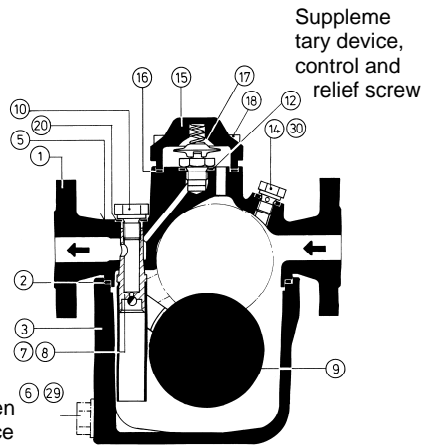

Type WU-1004, PN 16, DN 15 – 50

Fig. 7

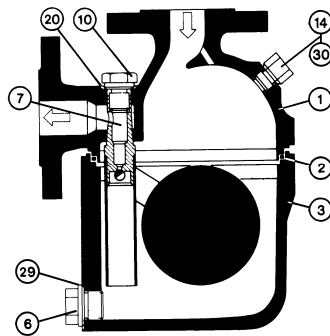

Type EF-1180, PN 25, DN 15 – 50

Fig. 8

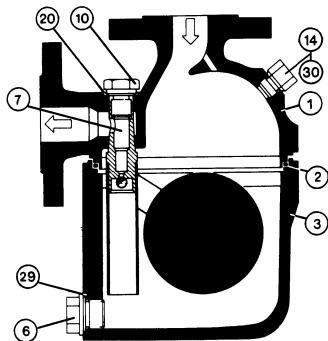

Type EF-1080-N, PN16, DN 15 – 50, stainless steel  
Type EF-1180-N, PN25, DN 15 – 50, stainless steel

Fig. 9

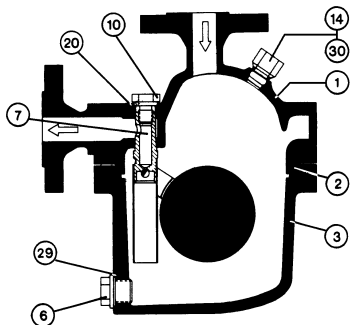

Type EF-1280-N, PN40, DN 25–50, stainless steel

Fig. 10

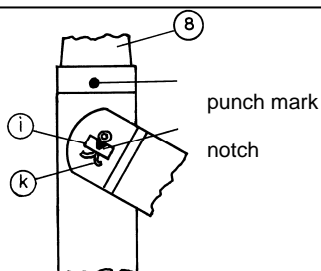

### 2.3 Functional limits of float control (PMO in bar)

Cross-section	Type 1001/1001-N 1080/1080-N		Type 1002/1004		Type 1101-N/ 1180/1180-N		Type 1201-N/ 1280-N	
	H	C	H	C	H	C	H	C
Id					20	25		
IId					18	23		
Ila							32	40
III	13	16	13	-	13	16	13	16
IV	11	14	11	-	11	14	11	14
V	2.5	2.8	2.5	-	2.5	2.8	2.5	2.8
VI	13	16	13	-	16	25	20	30
Vla	-	-	-	-	20	25	30	30
VII	12	16	12	-	16	23	16	23
VIIIa	4	5	4	-	4	5	4	5
VIIIb	4	4.5	4	-	4	4.5	4	4.5
SQ / SK	Special model. Design according to process data.							

### 2.4 Function / installation / venting / gas compensation

Due to its gravity, the condensate flows down to the deepest point, i.e. to the condensate trap housing. A rising condensate level lifts the float and the valve opening is opened through the float fork / rotary valve connection. When the condensate level drops, the control closes.

■ In the case of steam, automatic venting is advantageous (see section 2.5). For manual venting: loosen item (4) and/or (14) by a quarter turn.

■ For proper function of the float control with pressure gases, the gas in the condensate trap housing must be able to move into the gas space with the same operating pressure above the condensate trap (pressure compensation). For this purpose the screw or control valve (4) or (14) can be replaced by a cutting ring union and a compensating line leading upward can be installed.

■ In the case of pressure gases, a special gastight under-level float control is nearly exclusively used (if necessary, consult Rifax).

### 2.5 Venting via the automatic thermal vent valve (Figs. 4+6)

**Fig. 4:** Air and gases are vented inward, i.e. to the condensate outlet, in the startup and operating mode via the rugged bimetal control system.

**Fig. 6:** Quick-action startup and continuous venting with high capacity, also inward to the condensate outlet.

**Vent jet:** Rugged continuous venting to the condensate outlet. Not suitable for higher venting capacity.

### 3.0 Assembly

#### 3.1 Fitting position

The condensate trap hangs with the housing (3) facing down in the center of the pipeline (see Figs. 1 to 9). The top housing section (1) can remain in the pipeline when the float control is dismantled.

#### 3.2 Installation

■ The condensate trap is flange-mounted, screwed or welded into the condensate line between flanges according to design and type.

■ Remove protective caps from condensate inlet and outlet.

■ Fitting position according to Figs. 1 to 9 or section 3.1.

■ According to the direction of the arrow cast on the housing.

■ **Support:** In the case of size DN 40/50, ensure adequate support in front of and behind the condensate trap. Condensate trap weight approx. 28 kg.

■ To avoid down times, it is recommended that a shut-off device with a by-pass line be installed both in front of and behind the condensate trap.

#### 4.0 Startup

The pressure build-up and heating-up of the housing should not take place abruptly. If leaks occur due to so-called settling after the first startup, the screws (items 5, 6, 10, 14) can be retightened taking into account the indicated torque. Retightening may only be carried out when the housing is **depressurized** and at most **warm to the touch**.

## 5.0 Monitoring and checks

Malfunctions arise either as condensate backup or steam entry into the condensate system.

**Condensate backup** can be determined: a) with screw (4) or (14): loosen item (4) or (14) by only a quarter turn ensuring that no condensate escapes; and b) in the case of steam applications, with a surface thermometer on the housing (if necessary, consult RIFOX).

**Steam or gas entry** can be determined with an ultrasonic measuring device, e.g. RIFOX – USD 9050, and in the steam section also with a surface thermometer. In the case of steam entry, check control (7) and (17) and replace if necessary (consult RIFOX if required).

## 6.0 Maintenance / inspection

### 6.1 Opening the condensate trap and dismantling the float control

1. The condensate trap must be depressurized. Shut off the system securely in front of and behind the condensate trap.
2. Release any remaining pressure in the housing by loosening screw (4) or (14) by only a quarter turn.
3. Loosen housing bolts (5) evenly crosswise. Pull down bottom housing section (3) (top housing section [1] remains in the pipeline).
4. Loosen support bolt (10) and screw out 1 to 2 turns.
5. Tap gently on the front end of the support bolt (10) with a plastic mallet. This loosens the control from the conical housing seat.
6. Screw out support bolt (8) completely. Remove float control.

### 6.2 Disassembling and cleaning the float control

1. After removing the cotter pin (k), the rotary valve (i) is simply pulled out to the side.
2. Clean the parts using, for example, benzine.
3. Check the rotary valve (i) for wear along the sealing edge. If wear is detected, the support body (8) together with the rotary valve (i) must be replaced. A careful leak test must be carried out by RIFOX.
4. During assembly ensure that the notch in the rotary valve (i) points to the punch mark on the support body (8) and the cotter pin (k) is inserted and secured again carefully.
5. It must be possible to move the float up and down easily by hand.

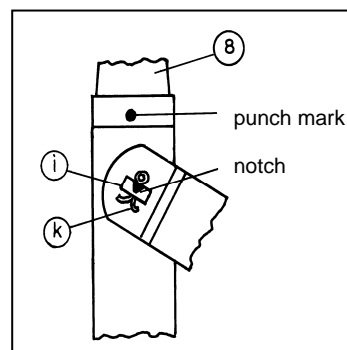

### 6.3 Installing the control and assembling the condensate trap

1. The complete float control is inserted into the conical housing seat with the support body (8). It must be ensured here that the float is positioned in the center of the housing.
2. The support body (8) is fixed in the conical housing seat with a gentle tap of the plastic mallet on the front end of the immersion tube.
3. Screw in support bolt (10) with gasket (20) and tighten with a standard ring wrench. For tightening torque see page 4
4. Check the housing gasket (2) and replace necessary.
5. Tighten the housing bolts (5) evenly crosswise. For tightening torque see page 4.

### 6.4 Care and maintenance, spare parts

- In the case of a great risk of dirt accumulation, the housing should be rinsed thoroughly from time to time, but while depressurized. If necessary, the float control should also be checked according to section 6.2.
- Dirt that has collected in the housing can be emptied after removal of the screw plug (6).
- In special cases it may be useful to install a separate dirt trap upstream.
- In most cases the float control does not require special care. Maintenance primarily depends on the wear resistance of the valve seal. See sections 6.1 and 6.2 in this connection.

### Spare parts: Only genuine spare parts may be used.

Item	Designation	Dimension / DIN	Design / material
2	Housing gasket for	138 x 132 158 x 150 195 x 188 197 x 188	a) Cu b) soft iron c) stainless steel profiled graphite d) PTFE a) PTFE b) stainless steel profiled graphite a) Cu b) soft iron c) stainless steel profiled graphite PTFE
4	Control valve	G ¼	standard stainless steel
5	Housing bolts with nuts	DN 15-25 (depending on type) 1) M 12 2) M 14 3) M 16 DN 40/50 (depending on type) 1) M 16 2) M 20	a) 8.8 b) A4-70
6	Drain plug	G ½, DIN 910	steel 5.8
7	Complete float control	For size see front end of support bolt item 10	a) standard stainless steel b) 1.4571
8	Support bolt compl. with rotary valve	Ditto	a) standard stainless steel b) 1.4571
9	Float assembly with fork	Ditto	a) 1.4301 b) 1.4571
10	Support bolt	1) G ¼ 2) M 18 x 1.5	a) 1.4104 b) 1.4571
14	Control screw	G ¼	a) 1.4104 b) 1.4571
16	Seal for vent cap	60 x 52	graphite with plate

17	a) Complete plug valve b) Capsule with valve body	Standard, s = 2, h = 1.5 standard, type S	Standard stainless steel / bimetal stainless steel / HC4
18	Set of hexagon socket screws	M 8	A4-70
20	Seal for support bolt	1) D = 22 2) D = 28	a) Cu b) soft iron c) stainless steel profiled graphite d) PTFE
28	Seal for plug valve or valve body capsule	for G 3/8	a) Cu b) soft iron
29	Seal for drain plug	for G 1/2	a) Cu b) soft iron c) stainless steel profiled graphite
30	Seal for control valve / control screw	dia = 18	a) Cu b) soft iron c) stainless steel profiled graphite d) PTFE

### 6.5 Screw tightening torque (at room temperature, coat thread with temperature-resistant lubricant)

Type	DN	Housing gasket Item 2	Screws Item 5	Torque Item 5	Seal Item 12/20	Torque Item 10
1002/ 1004	15 - 25	Cu and soft iron	M 12, 8.8	60 Nm	Cu and soft iron	60 Nm
1002/ 1004	40 / 50	a) Cu b) soft iron	M 16, A4-70	a) 100-110 Nm b) 80 Nm	Cu and soft iron	100 Nm
1001-N / 1080-N	15 - 25	a) PTFE b) stainless steel profiled graphite	M 14, A4-70	a) 25 Nm b) 60 Nm	a) PTFE b) stainless steel profiled graphite	a) 12 Nm b) 20 Nm
1001-N / 1080-N	40 / 50	a) PTFE b) stainless steel profiled graphite	M 16, A4-70	a) 25 Nm b) 70 Nm	a) PTFE b) stainless steel profiled graphite	a) 15-20 Nm b) 40 Nm
1101-N / 1180-N	15 - 25	a) PTFE b) stainless steel profiled graphite	M 14, A4-70	a) 25 Nm b) 60 Nm	a) PTFE b) stainless steel profiled graphite	a) 12 Nm b) 20 Nm
1001-N / 1080-N	40 / 50	a) PTFE b) stainless steel profiled graphite	M 16, A4-70	a) 25 Nm b) 60 Nm	a) PTFE b) stainless steel profiled graphite	a) 15-20 Nm b) 40 Nm
1180	15 - 25	Cu and soft iron	M 14, 8.8	90 Nm	Cu and soft iron	60 Nm
1180	40 / 50	a) Cu b) soft iron	M 16, A4-70	a) 100-110 Nm b) 80 Nm	Cu and soft iron	100 Nm
1201-N / 1280-N	15 - 25	a) PTFE b) stainless steel profiled graphite	M 16, A4-70	a) 25 Nm b) 70 Nm	a) PTFE b) stainless steel profiled graphite	a) 12 Nm b) 20 Nm
1201-N / 1280-N	40 / 50	a) PTFE b) stainless steel profiled graphite	M 20, A4-70	a) 40 Nm b) 90 Nm	a) PTFE b) stainless steel profiled graphite	a) 15-20 Nm b) 40 Nm

### 7.0 Declaration of conformity CE

We declare conformity with Directive 97/23/EC of 29.05.1997 for the following pressure equipment:

#### Float-controlled condensate trap type

1002 / 1004	DN 15 - 25:	Art. 3, par. 3: no CE-Mark
1101 / 1180	DN 15 - 25:	Art. 3, par. 3: no CE-Mark
1101 / 1180	DN 40 / 50:	Cat. 2, fluid group 1, module H
1001-N / 1101-N / 1080-N / 1180-N	DN 15 - 25:	Art. 3, par. 3: no CE-Mark
1001-N / 1101-N / 1080-N / 1180-N	DN 40 / 50:	Cat. 2, fluid group 1, module H
1201-N / 1280-N	DN 15 - 25:	Art. 3, par. 3: no CE-Mark
1201-N / 1280-N	DN 40 / 50:	Cat. 2, fluid group 1, module H

The pressure equipment described is a pressure-keeping component in accordance with Article 1, 2.1.4. Applied conformity assessment procedure according to Annex III.

Designated office: Lloyd's Register Quality Assurance GmbH, Mönkebergstr. 27, D-20095, Hamburg, Germany, identification no. 0525.

In the case that the equipment is modified without our approval, this declaration shall no longer be valid.

RIFOX – Hans Richter GmbH – Spezialarmaturen

  
Management

  
Quality Assurance



**RIFOX - Hans Richter GmbH Spezialarmaturen**

D - 28082 Bremen · Postfach 11 02 45 · Telefon +49 421/4 99 75 - 0 · Fax +49 421/4 99 75 - 40  
www.rifox.de · e-mail: contact@rifox.de

