

## Operating Manual

### For fully automatic fine dryer and fine filter

**Type** : TG 5051  
**Connections** : flanges DN 20 / 25, socket thread G $\frac{1}{2}$ " , G $\frac{3}{4}$ " , G1"  
**Series** : from production no.: \_\_\_\_\_

#### 1.0 Safety instructions

##### 1.1 Proper use

Any improper use, intervention in the design and deviation from the design data automatically lead to termination of the warranty. The fully automatic fine dryer and fine filter are designed for the discharge of drip moisture (condensate / water / oil) and dirt particles from the flow medium (steam / compressed air / pressure gases). Any other use is not permissible. The manufacturer is not liable for damage resulting from any other use. The user or operator bears the risk in this case. This also applies analogously to incorrect assembly, startup, use and maintenance.

##### 1.2 Warnings and symbols

- Personal risk due to escaping operating medium as well as because of pressure and temperature. Failure to comply with these warnings results in the risk of accidents.
- Follow the instructions in this operating manual.
- ▲ **Warning symbol:** The operator must ensure that this operating manual and, if necessary, other relevant documents are available on site.
- Only qualified personnel may be assigned to work in this connection.
- Any mode of operation that may impair safety must be avoided.

#### 2.0 General description and use

##### 2.1 Design and function of the fine dryer and fine filter

Drip moisture and dirt particles are centrifuged through the self-regulating tangential centrifugal nozzle and collect at the bottom in the screened collector.

Drip moisture is discharged and transmitted to the outside under pressure via the built-in automatic vent valve (rotary valve float control). Fine dirt particles of up to 25 microns are held back by means of a sintered metal fine filter.

The sintered metal filter can be replaced with a fabric sieve with supporting jacket.

The self-regulating tangential centrifugal nozzle automatically adjusts to pressure and volume fluctuations. The automatic vent valve has only a single moving point because the rotary valve is a revolute joint and a shut-off device at the same time.

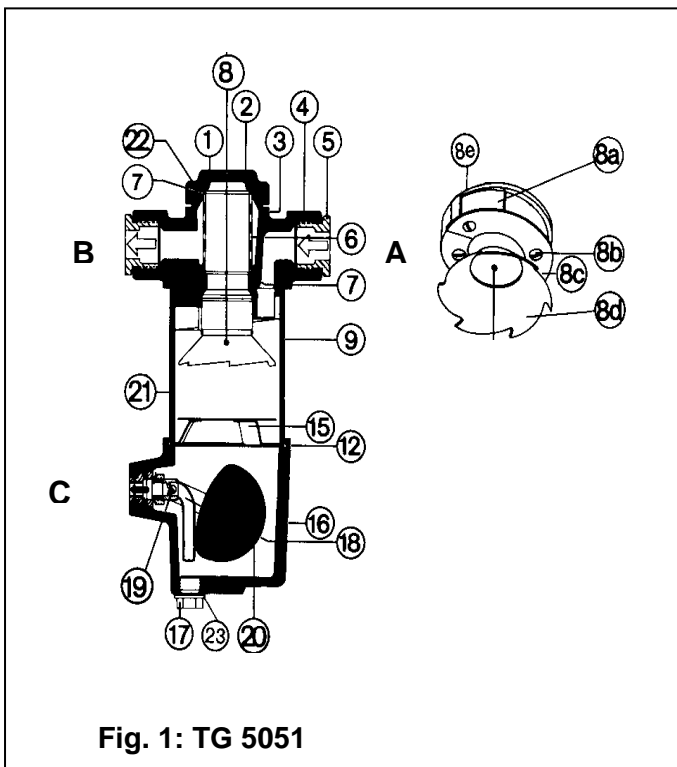



Item	Designation	Mat./dimension
1	Housing sealing plug	GK-AISI12
3	Sealing plug gasket	soft material/70x60
4	Top housing section with stud bolts	GK-AISI12
5	Screw socket	galvanized steel ½",3/4",1"
6	Filter cartridge	sintered bronze 70x48
7	Filter gaskets	soft material / 48x40
8	Centrifugal nozzle compl.	GK-AISI12 /stainless steel
8a	Elastic nozzle wall	stainless steel
8b	Screws for nozzle mounting and cover plate	stainless steel
8c	Cover plate	stainless steel
8d	Nozzle with screen tube	GK-AISI12 / stainless steel
8e	O-ring seal	buna N
9	Intermediate tube	Al Mg3
12	Intermediate tube seals	soft material 110x100
15	Collector	stainless steel
16	Bottom housing section	GK-AISI12
17	Drain plug	galvanized steel, G1/2
18	Float control compl.	stainless steel
19	Support body + rotary valve compl.	stainless steel
20	Float with fork	stainless steel
21	Stud bolt	C45K-5D galvanized, M10x178
22	Hexagon nut with spring washer	M10, galvanized
23	Gasket	Al 28x21

## 2.2 Identification / operating limits (see rating plate or designation on housing)

### 2.3 Functional limits of standard float control (PMO in bar) with liquid density of 1.0 kg/dm<sup>3</sup>

Type	Cross-section	Admission pressure in bar
TG 5051	C	12

## 3.0 Assembly

### 3.1 Fitting position

In the case of horizontal flow, the fully automatic fine dryer and fine filter are installed in the pipeline as close as possible in front of the loads. The upstream system should be predrained at low points and in long pipeline sections by means of float control condensate traps.

In the case of special, more extensive requirements regarding the flow medium, it may be necessary to install special microfilters after the fully automatic fine dryer, possibly also adsorption or cold dryers to reduce the relative moisture.

### 3.2 Installation



- Prior to installation of the unit depressurize the system.
- Remove protective caps from inlet (A), outlet (B) and condensate outlet (C).
- Blow out pipes and hoses well.
- Always install unit at the coldest point, i.e. close to and in front of the load.
- Flow direction horizontal in direction of arrow (note arrow on top section (4) )  
and in case of vertical position of the housing central axis.
- G1/4 condensate outlet (C) on side.

## 4.0 Startup

The pressure buildup and heating up of the housing should not take place abruptly.

If leaks occur after the initial startup due to so-called settling, the screws (items 21 /19) may have to be retightened while taking into account the indicated torques. Retightening may only be carried out when the housing is depressurized and warm to the touch.



### Note:

Prior to the startup fill liquid for the float control into the system until it comes out of the condensate outlet (C).

## 5.0 Malfunctions

Malfunctions of the condensate trap arise either in the form of a condensate backup due to a defect in the float control or as declining throughput capacity, e.g. because of dirt accumulation in the sintered metal filter (6).



Condensate backup: Condensate is transported to the load (the product becomes wet).

Dismantle and check the float control.

Declining throughput capacity: Sintered metal filter (6) is dirty (pressure drop).

## 6.0 Maintenance / inspection / spare parts

### 6.1 Cleaning the filter cartridge

According to the degree of dirt accumulation in the air or gases to be cleaned, it is expedient to rinse the filter (6) thoroughly or to blow it out with compressed air. The filter can be taken out easily in an upward direction after loosening the filter cover (1). When reinserting the filter (6), ensure that the filter gaskets (7) remain undamaged and the filter (6) fits into the extension correctly and is not tilted.

### 6.2 Readjusting the elastic nozzle wall in type 5051

After a long operating period it may be necessary, particularly in the case of a pulsating flow, to readjust the elastic nozzle wall (h1). After removing the top housing section (4), simply pull the spring case (h), consisting of the elastic nozzle wall (h1) and spring holder with square retention pin (h2), out of the swirl nozzle. To readjust the elastic nozzle wall (h1), press the square retention pin (h2) out of the square holder, retighten a quarter turn (counterclockwise) using a screwdriver and reinsert in the square holder. Now the spring case tensed in this manner can simply be pressed into the swirl nozzle again.

Fig. 3:

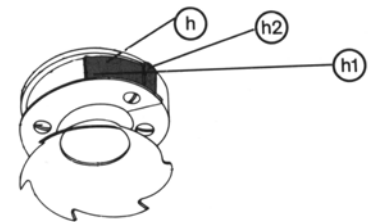

### 6.3 Cleaning the bottom housing section

Remove impure condensate / water / oil from the bottom housing section (16) through the dirt drain plug (17) or dirt drain valve. In the event of difficult operating conditions, e.g. with condensate that is extremely dirty or has a high oil content, it is necessary to clean the bottom housing section (16), including the float control, with benzene. The time intervals depend on the degree of dirt accumulation in the condensate. In the case of condensate with a high oil content, an additional oil extraction hole may have to be drilled in the immersion tube (18).



### 6.4 Dismantling the bottom housing section

- Depressurize the system, including TG, prior to dismantling.
- Loosen housing bolts.
- Loosen side condensate discharge line at outlet (C).
- Pull down bottom housing section (16) with intermediate tube (9).
- The top housing section (4) can remain in the pipeline.
- After removing the intermediate tube (9) and the collector (15), you can dismantle the float control.



### 6.5 Dismantling the float control

This is carried out using a centering aid, which can be obtained from us.

The centering aid must be turned through the thread of the bushing. After pushing through a small space without thread, the centering aid is inserted 2-3 turns into the threaded hole of the support body (19). With a few light taps with a mallet on the head of the centering aid (Fig. 4) the control is driven out of the conical seat while lifting the float (20).

The float control consists of: support body + rotary valve + cotter pin (19) and float with fork (20).

Fig. 4:

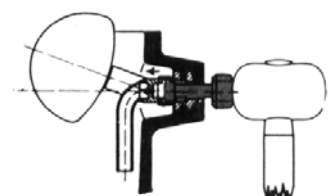

## 6.6 Disassembling the float control

After removal of the cotter pin the rotary valve (19) is simply pulled out and the individual parts can be cleaned. After the individual parts are cleaned and checked for wear, you must ensure when assembling the control (Fig. 5) that the notch on the rotary valve (19) points to the punch mark on the support body and the cotter pin is reinserted carefully and pushed apart.

Fig. 5:

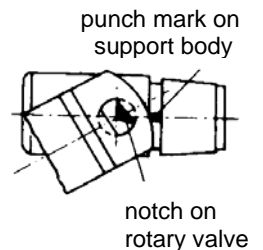

## 6.7 Inserting the float control

The control is inserted with the support body in the conical housing seat. The centering aid must be turned through the thread of the bushing on the outlet (C). After pushing through a small space without thread, the centering aid is inserted in the thread of the support body (19) and made hand-tight by turning it clockwise in the conical housing seat (Fig. 6). After that the centering aid is screwed out. The immersion tube must always point vertically down.

Fig. 6:

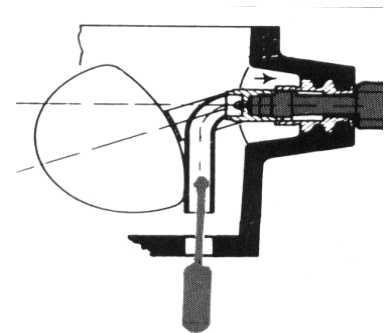

This is done with the following aids:

Remove the dirt drain plug (17) and insert a screwdriver through the thread opening, which is then clear, into the immersion tube.

## 6.8 Assembly

The collector (15) is mounted onto the bottom housing section (16) and the intermediate tube (9) is installed on the collector (gaskets below and above the collector must be protected against damage). After that the bottom housing section (16), including the intermediate tube (9), is connected to the top housing section (4). The housing bolts are then tightened crosswise by hand using an open-jawed wrench – for tightening torques see table. The side condensate discharge line is connected again (see 3.2).

## 6.9 Care and maintenance, special instructions

- + The float control does not require any special care in most cases. In the case of media with a high oil content, however, it may be necessary to dismantle the bottom housing section according to point 6.4 now and again and remove the oil residues. This applies in a similar manner also to the float control (point 6.5 and 6.6). In the event of great oil accumulation, the float control must be inserted in the immersion tube with an oil extraction hole.
- + With pressure gases it is advantageous to install a gastight under-level float control.
- + The intake capacity of the filter cartridge (6) for solid particles is limited. Regular cleaning in accordance with point 6.1 is recommended. In the case of a high proportion of dirt particles or to achieve minimal pressure loss, the filter cartridge can be replaced with the supplementary device, "fabric sieve with supporting jacket".

**Screw tightening torque** (at room temperature coat thread with a temperature-resistant lubricant)

Type	Item 4, housing sealing plug screws	Item 21, threaded rods
TG 5051	20 Nm	15 Nm

## 7.0 Conformity assessment

In accordance with Pressure Equipment Directive 97/23/EC of May 29, 1997, the described pressure equipment, TG 5051, TG 5061 and TG 5061-N, falls under Art. 3 subsection 3 and therefore does not bear any CE mark.