

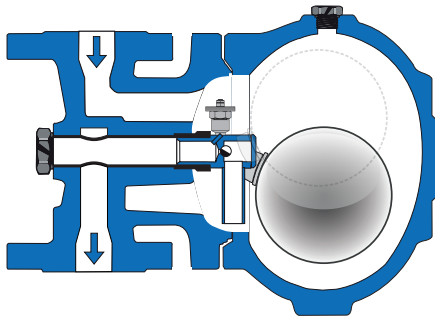

RIFOmat Float-Controlled Trap - Model Vario

1200

PN 40



Vario SO



Vario SU



Vario WR



Vario WL

Housing-Material: GP240GH

Connections/Dimensions: Flange DN 15/20/25/40/50, PN 40, connecting dimensions according to EN 1092-2. End to end dimensions acc. DIN 3548, LK. Dimensions acc. ANSI B16.5

Nominal pressure stage: PN 40

Operation-Limits:

Max. working pressure bar g	40	37	35	32	28	24	21
Max working temperature °C	<120	150	200	250	300	350	400

Media: Steam, air, gases on request.

Function: Increasing level opens and decreasing level closes the outlet without delay, independent of pressure and temperature fluctuations. The rotary slide valve is both swivel joint and shut-off device.

Special characteristics: A float-controlled trap for all flow directions and face to face length to DIN 3548, short series. The RIFOmat-Vario will be assembled as specified by customer. A change of flow direction can be accomplished in situ by merely rotating the housing flange and repositioning the float control unit.

Installation: Vertical or horizontal direction of flow (type WR, WI, SO, SU) as per illustrations

Additional equipment against extra price:

- RIFObi start up and permanent venting to interior, pressure diff. max. 32 bar
- Gastight under-level float control
- Vent jet (interior)
- Reflective water level sight glass (RWG) up to 243°C.
- Drain plug
- Blow off valve for contaminants instead drain plug
- Check valve in outlet flange
- Bottom control valve to check min. condensate level
- Top control valve instead control screw
- Float control assembly for special applications (gases)

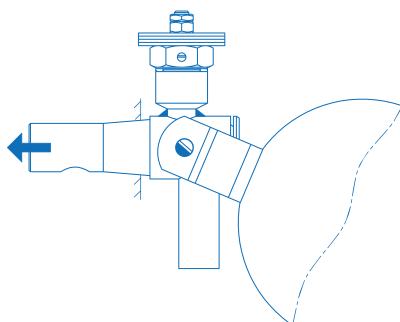

Automatic venting during start-up phase followed by continuous venting. Rising temperature closes, while decreasing temperature opens the passage.

Performance

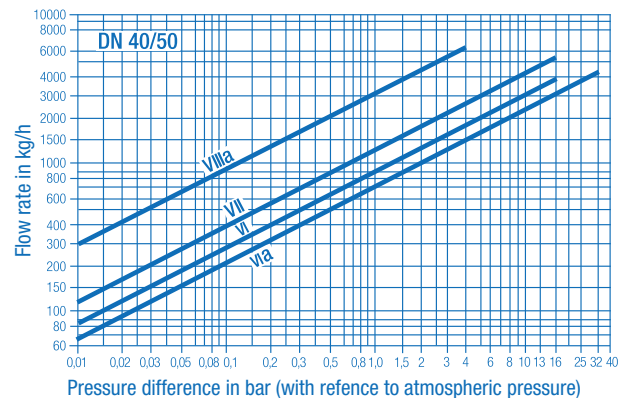
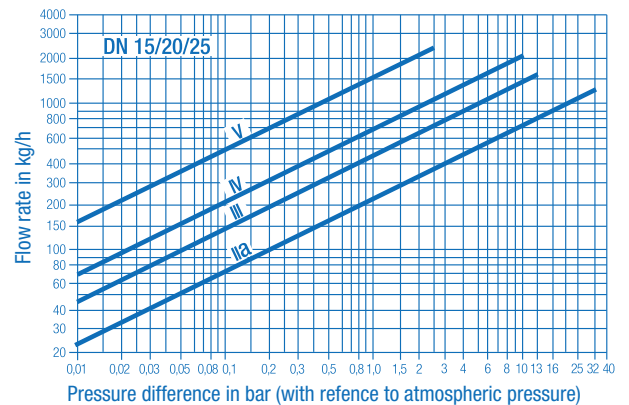

For the cold condensate the flow rate is higher because of medium temperature and density.

Fuction-limit:	max. line pressure in bar g	
	Cross section	Steam
II a	32	40
III	13	15
IV	11	14
V	2,5	3
VI	17	24
VI a	31	32
VII	16	23
VIII a	4	5

CE - mark:

The pressure equipment described is a pressure-keeping component in accordance with the Pressure Vessel Directive 97/23/EC of DN15-25: acc. art.3, sub3, no CE-mark. DN40/50: Conformity through the ident. mark CE 0525.

Please state the following when making inquiries / placing orders: Medium, density, initial pressure, counter pressure, temperature, quantity of condensation (kg/h).

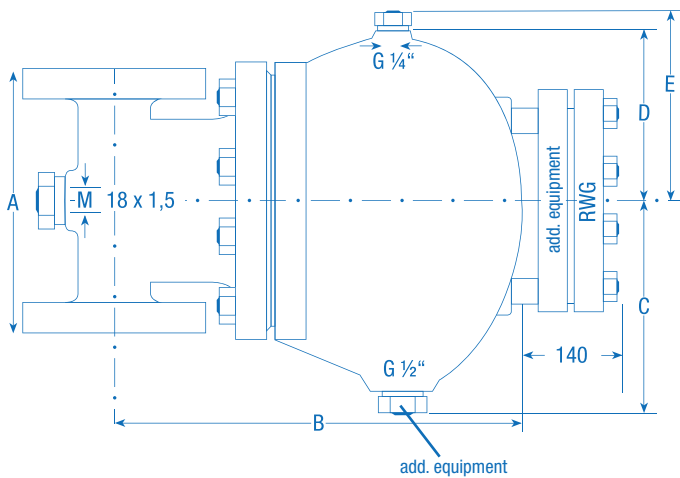

Dimensions (in mm), Weight (in kg)

DN	15	20	25	40	50
A	150	150	160	230	230
B	240	240	240	310	310
C	115	115	115	150	150
D	95	95	95	135	135
E	105	105	105	145	145
weight	13	13,5	14	34,5	35
weight with RWG	14	14,5	15	36,5	37

Spare Parts

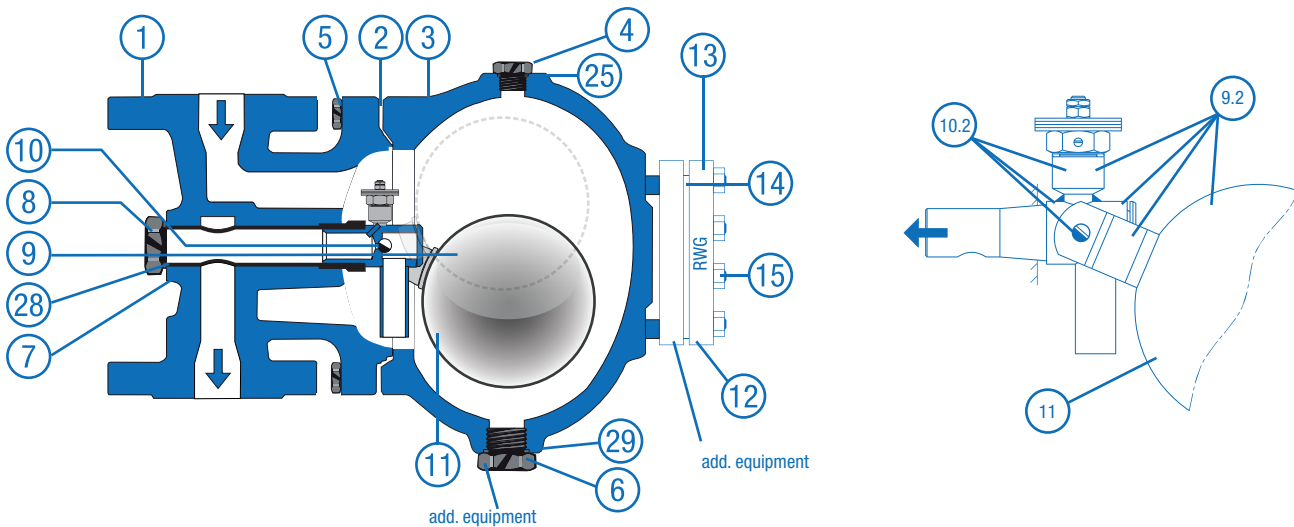

1 **Housing flange:** GP240GH

2 **Seal:** Soft iron

3 **Main housing:** GP240GH

4 **Control screw:** SS 1.4104

5 **Set of stud bolts and nuts:** A4-70, DIN 939/934

6 **Drain plug:** G 1/2", 5.8, DIN 910

7 **Protective sleeve:** SS 1.4057

8 **Support bolt:** SS 1.4104

9.0 **Float control assembly**:** SS 1.4057/1.4112/1.4301/1.4104 (1.4571)*

9.2 **Complete Float Control with built-on bi-metallic capsule venting device RIFObi**:**
SS 1.4057/1.4112/1.4301/1.4104/ SS-Hastelloy

10.0 **Support assembly with rotary valve and cotter pin**:**
SS 1.4057/1.4112/1.4301/1.4104 (1.4571)*

10.2 **Complete Supporting Structure incl. rotary slide valve, cotter pin and built-on RIFObi-metallic capsule venting device**:**
SS 1.4057/1.4112/1.4301/1.4104

11 **Float with lever:** SS 1.4301 (1.4571)*

12 **Maxoglas:** as per DIN 7081

13 **RWG frame:** P265GH

14 **2 gaskets for RWG:** poor graphite with SS

15 **Set of stud bolts and nuts:** A4-70, DIN 938/934

25 **Seal:** Soft iron

28 **Seal:** Soft iron

29 **Seal:** Soft iron

To ensure correct parts delivery, specify part number, works standard-sheet number, DN, and for control components the cross-section.

*Depending on operating conditions

**Due to sealing requirements marked items cannot be supplied as individual parts.